

AVAMORE 7, 10 & 14 COMBINED STAND & WASTE

POTATO & ROOT VEGETABLE PEELERS

Our range of DSW series vegetable peelers with their combined stand and waste interceptor basket, both made in stainless steel, are ideal for customers with environmental and ergonomic requirements are high. With a choice of three capacities and two model variants there is a choice twelve designs to meet your every need.

Quick and Easy to use

Vegetables are simply poured through the splash lid opening and automatically discharged when the door is opened. A full load of new potatoes can be prepared in one to two minutes and late season potatoes in three to four minutes, producing far less waste than hand peeling. Swedes, turnips, carrots and other root vegetables can be prepared just as quickly.

Hygienic Construction

The body and abrasive liner are manufactured in stainless steel. All other components in the peeling chamber are manufactured in corrosion resistant, paint free aluminium. The abrasive peeling plate is easily removed after use to dispose of any residual waste.

Simple to Install

There are no bolts required to secure these floor-standing models with four large adjustable feet they will stand on nearly all floors. There is one waste outlet position under the waste tank, this outlet can however be positioned through nearly the whole 360°. The peeling chamber and discharge chute can be rotated through 270°, allowing optimum ease of installation. Making the AVAMORE vegetable peeler extremely versatile.

All AVAMORE DSW series vegetable peelers are supplied complete with lifting hooks for the peeling plate, inlet hose with 3/4BSP fitting and \varnothing 40mm female swivel outlet.

Ergonomic

With the lower height of these models, 560mm discharge height, offers the user the advantage of easy access to the peeling chamber at under 950mm high and allowing for less strain while filling these vegetable peelers.

Safety

Fitted with push buttons 'start' & 'stop', which incorporate a no-volt release device to avoid unintentional start up.

Models

7, 10 & 14DSW – Combined Stand & Waste Interceptor models
7, 10 & 14DSWT – as above fitted with an electronic timer

Options

Gear Drive

Clear Splash Lid

Accessories

Timers electronic 0-7 minutes wall mounted.

Switch/Isolators wall mounted

Switch/Isolators with integral timer wall mounted

Waste Pipes & Kits – a range of rigid and flexible outlet pipes.

Quality Assurance

All our products are CE approved.



14DSWT model in the centre of a sample of our range of vegetable peelers.

SPECIFICATION

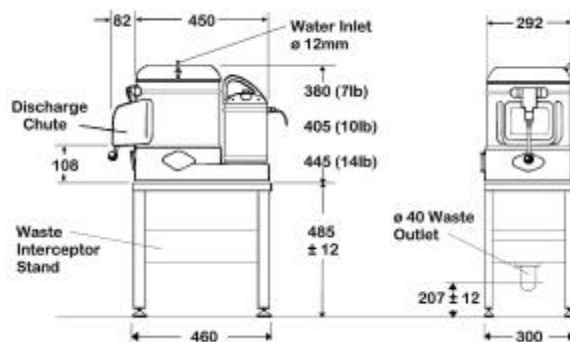

| Model | 7 SERIES | 10SERIES | 14 SERIES |
|--|---|-------------------|-------------------|
| Capacity | Up to 3Kg | Up to 4.5kg | Up to 6kg |
| Water Connection | 12 mm hose connector | | |
| Water Consumption - standard | 1 litre/minute | 1.2 litres/minute | 1.3 litres/minute |
| Waste Outlet standard | 40 mm ABS solvent type | | |
| Waste Outlet optional | 1.5 BSP female | | |
| Motor | 180W | 180W | 250W |
| Noise Emission | 70dB | | |
| Electrical Supply others on request | 220-240V, 1ph, 50Hz. 220/415V, 3ph, 50Hz | | |
| Weight, net | 28.5kg | 29kg | 30kg |
| Packed weight | 34.5kg | 35kg | 36kg |
| Packed dimensions | Peeler 510x390x625, 0.11M ³ | | |
| Packed dimensions | Stand 470x310x470, 0.07M ³ | | |

In the interest of product development we reserve the right to alter specifications without prior notice.



Avamore Catering Equipment is a trading name of AVAMORE ENGINEERING LIMITED

Dragon Lodge, The Reeds Road
Millbridge, Frensham,
Surrey, GU10 3DQ, UK
Telephone +44 (0) 1252 795404
Facsimile +44 (0) 1252 792780
Email sales@avamore.com
Web: www.avamore.com

