

AVAMORE 7, 10 & 14 SERIES

POTATO & ROOT VEGETABLE PEELERS

Our versatile and compact peelers are ideal for kitchens and preparation rooms where space is limited. With a choice of three capacities and six model variants there is a choice eighteen designs to meet your every need and budget.

Quick and Easy to use

Vegetables are simply poured through the splash lid opening and automatically discharged when the door is opened. A full load of new potatoes can be prepared in one to two minutes and late season potatoes in three to four minutes, producing far less waste than hand peeling. Swedes, turnips, carrots and other root vegetables can be prepared just as quickly.

Hygienic Construction

The body and abrasive liner are manufactured in stainless steel. All other components in the peeling chamber are manufactured in corrosion resistant, paint free aluminium. The abrasive peeling plate is easily removed after use to dispose of any residual waste.

Simple to Install

Our unique design incorporates a handle allowing the worktop model to be easily moved to alternative positions. These peelers are so versatile you can also permanently install them with a single bolt to a worktop. Three bolts are all that is required to secure the floor standing models. There are three options of waste outlet position, to the front and either side, the peeling chamber and discharge chute can be rotated through 270°, allowing optimum ease of installation. Making the AVAMORE vegetable peeler the most versatile available.

All AVAMORE vegetable peelers are supplied complete with lifting hooks for the peeling plate, inlet hose with fittings and floor securing bolts where required.

Safety

Fitted with push buttons 'start' & 'stop', which incorporate a no-volt release device to avoid unintentional start up.

Models

- 7, 10 & 14DB – work top models
- 7, 10 & 14DBT – work top models with electronic timer
- 7, 10 & 14DPS – floor model with discharge height 560mm
- 7, 10 & 14DPST – as above fitted with an electronic timer
- 7, 10 & 14DPL – floor model with discharge height 965 mm
- 7, 10 & 14DPLT – as above fitted with an electronic timer

Options

- Gear Drive
- Clear Splash Lid

Accessories

- Timers** electronic 0-7 minutes wall mounted.
- Switch/Isolators** wall mounted
- Switch/Isolators with integral timer** wall mounted
- Mobile Stands** in stainless steel for worktop models.
- Sink Peel Sieve** to collect waste from worktop models.
- Waste Dilution Unit** directs a powerful jet of water through the waste outlet, the design incorporates an air-break.
- Waste Interceptor Tank** for filtering of waste.
- Waste Pipes & Kits** – a range of rigid and flexible outlet pipes.

Quality Assurance

All our products are CE approved.



7D in foreground, with a sample of our range of vegetable peelers

SPECIFICATION

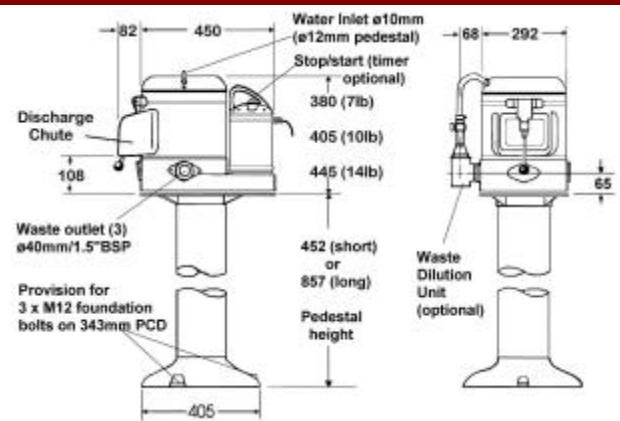

Model	7 SERIES	10SERIES	14 SERIES
Capacity	Up to 3Kg	Up to 4.5kg	Up to 6kg
Water Connection	10 mm hose connector- worktop models		
Water Connection	12 mm hose connector – floor models		
Water Consumption - standard	1 litre/minute	1.2 litres/minute	1.3 litres/minute
- with waste dilution unit	3 litres/minute	3.5 litres/minute	4 litres/minute
Waste Outlet standard	40 mm ABS solvent type		
Waste Outlet optional	1.5 BSP female		
Motor	180W	180W	250W
Noise Emission	70dB		
Electrical Supply others on request	220-240V, 1ph, 50Hz. 220/415V, 3ph, 50Hz		
Weight, net	21kg	21.5kg	22.5kg
Packed weight	26kg	26.5kg	27.5kg
Packed dimensions	510x390x625, 0.11M ³		

In the interest of product development we reserve the right to alter specifications without prior notice.



Avamore Catering Equipment is a trading name of AVAMORE ENGINEERING LIMITED

Dragon Lodge, The Reeds Road
Millbridge, Frensham,
Surrey, GU10 3DQ, UK
Telephone +44 (0) 1252 795404
Facsimile +44 (0) 1252 792780
Email sales@avamore.com
Web: www.avamore.com

